

ASSM-112R Series is an array of 2-Way Power Splitters mounted on a 2RU Sub-Rack Tray (PN: R112B-2RU). Up to 16x of the Reactive Splitters (Model #: 112R-600-6000-QMA) can be mounted on a rack tray. Each of these splitters has an independent RF path. The Splitters have both Input and Output connectors on the same side which makes connection on a Rack Frame or H-Frame simple and straightforward. They cover all the traditional Cellular frequencies, including the CBRS, C-Bands and LTE-LAA. When mounted on a DAS Tray, they can be used to split signals coming out of Attenuator Modules into different zones in In-Building Systems. It also has a very low Insertion Loss with an outstanding VSWR at all three ports.

Each Assembly includes the following:

- **2RU Sub-Rack (PN: R112B-2RU)** – Holds up to 16x 2-Way Splitter Modules
- **2-Way Power Splitter with QMA Connectors (PN: 112R-600-6000-QMA)**

- Up to 16x 2-Way Splitter Modules on 2RU tray
- Each Splitter has independent RF Path
- Input & Output Connectors along the same side
- INPUT – QMA (F)
OUTPUT – QMA (F)
- **CBRS / C-Band / LTE-LAA** Ready
- Low PIM , -161dBc
- In Stock to low lead time delivery



SPECIFICATIONS for 2RU Sub-Rack

PN: R112B-2RU:

2-Way Splitter Module	16 (max)
Rack Space Needed	2 RU
Temperature Range	-30°C to 70°C
Weight	3.00 lbs
Dimensions	3.47"(H) x 19.00"(W) x 3.75"(D)

SPECIFICATIONS for 2-Way SPLITTER MODULE

PN: 112R-600-6000-QMA:

Frequency Range	600 MHz – 6000 MHz
Passband Insertion Loss	0.20dB (Over the theoretical loss 3dB)
VSWR	≤ 1.30 @ 600-960 MHz ≤ 1.25 @ 960-4200 MHz ≤ 1.30 @ 4200-6000 MHz
Power Handling	200 W (Avg)
Intermodulation (PIM - 3 rd)	-161 dBc (Typ) (2 Tones +43 dBm)
Impedance	50 Ohms
Temperature Range	-30°C to 70°C
Connector	IN - QMA(F) / OUT – QMA(F)
Weight	0.75 lbs
Dimensions (in)	3.34"(H) x 0.91"(W) x 2.36"(D)

Dimensions for 2-Way Power Splitter Module (PN: 112R-600-6000-QMA)

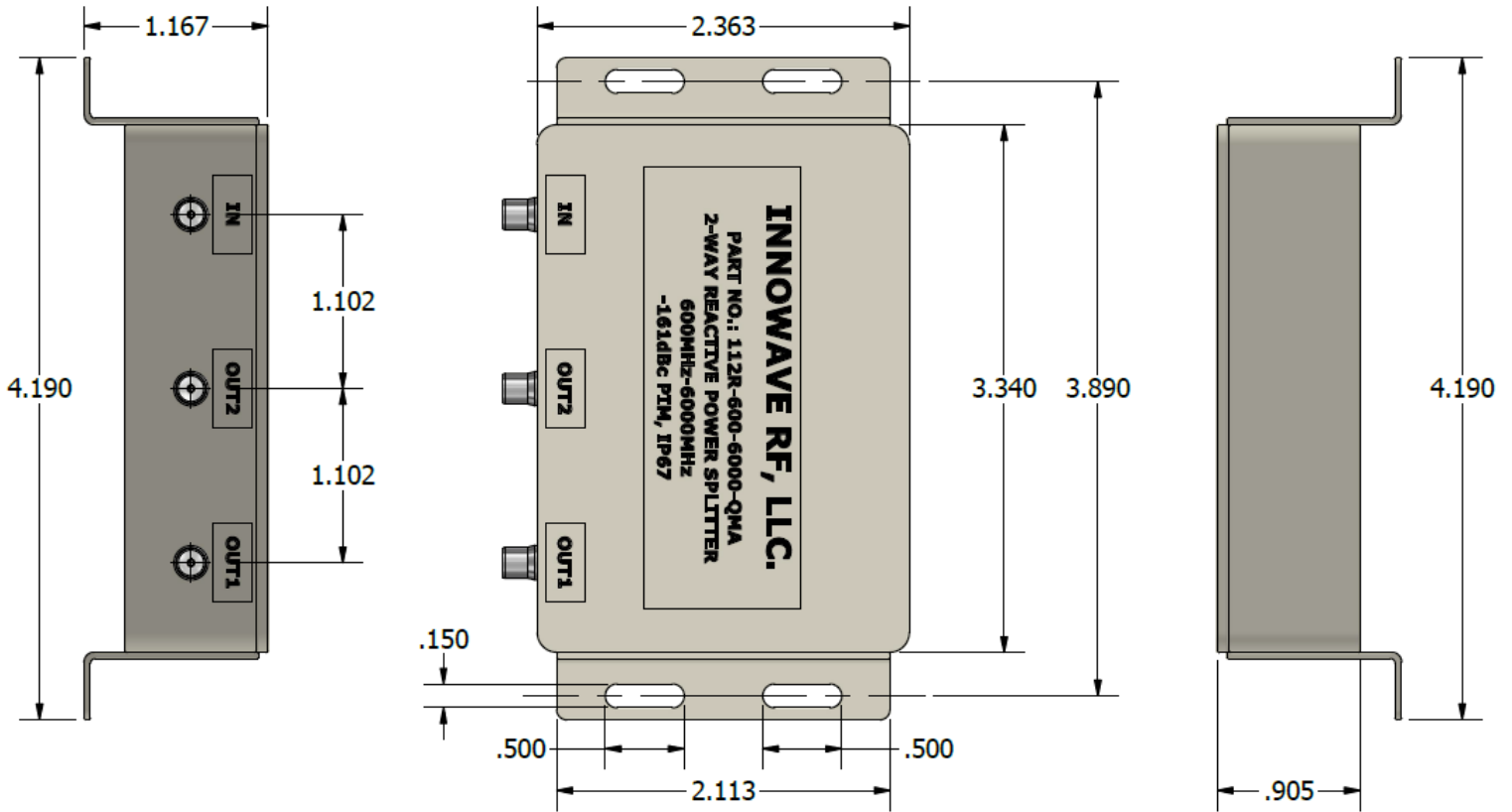

Dimensions for 2RU Sub-Rack (PN: R112B-2RU)

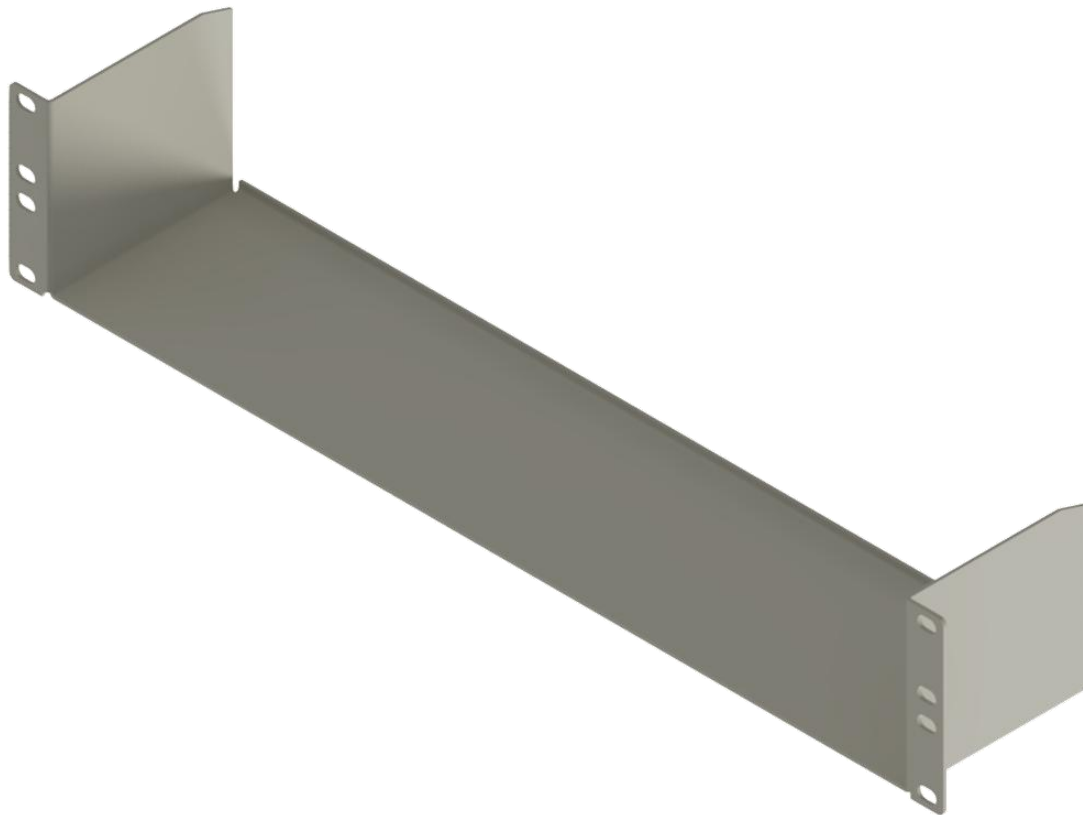
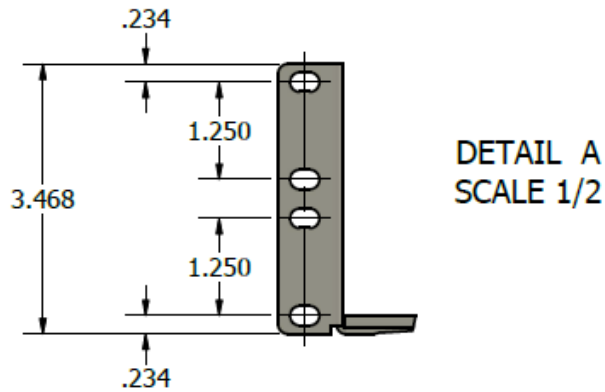
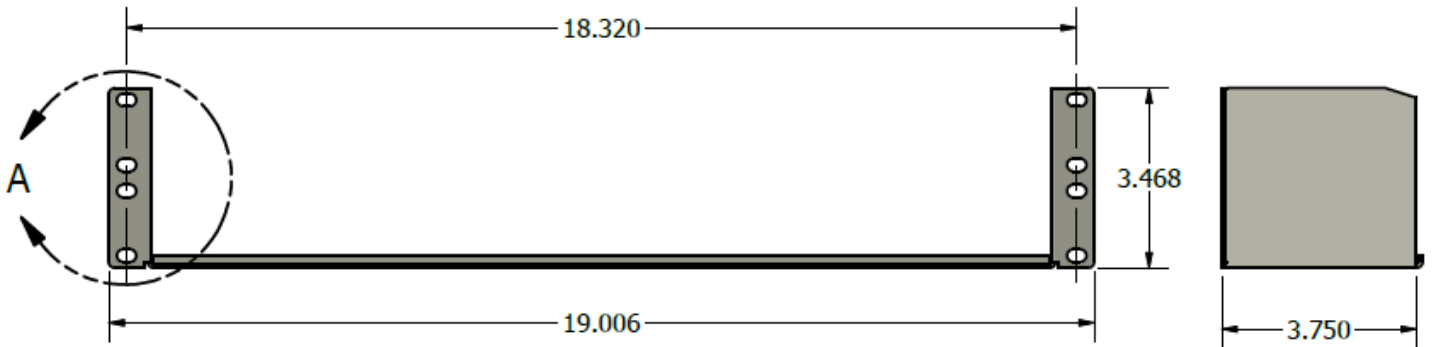

ASSM-112R-16-QMA with 16x 2-Way Power Splitters



ASSM-112R-16-QMA with 10x 2-Way Power Splitters

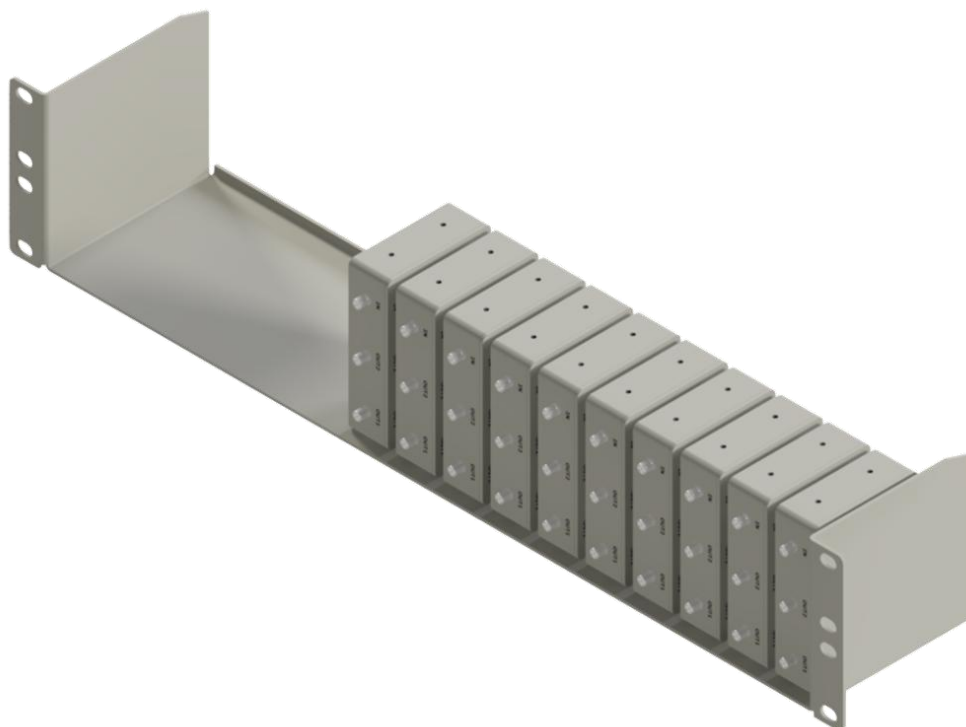

Please contact our sales department at 737-200-7090 or sales@InnowaveRF.com for any custom requirements.

© Innowave RF, LLC. All Rights Reserved. Specs can change without notice. Drawings are for reference purpose only.