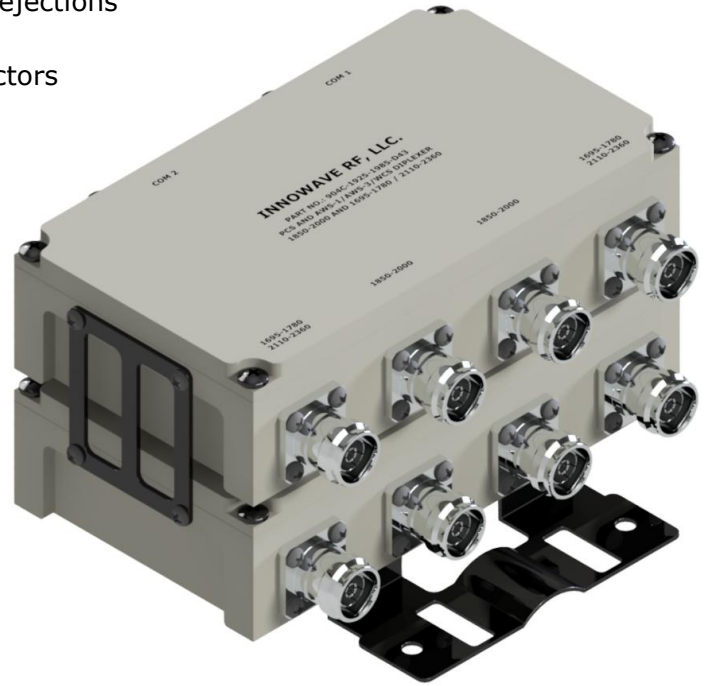

FEATURES:

- Splits or combines the **AWS-1 / AWS-3 / WCS Bands** (1695MHz–1780MHz & 2110MHz-2360MHz) and **PCS Band** (1850MHz–2000MHz)
- **Compact Design** with **Single/Stacked/Twin/Quad** combiner model for tight space applications
- Best-in-class Isolation between the 2 signals
- Very low Insertion Loss with superior out of band rejections
- Low-PIM with High Power Handling
- Available in 7/16 DIN, Mini-DIN and 4.3-10 Connectors
- **RoHS** Complaint, Weatherproof / Outdoor unit
- In Stock to low lead time delivery

ELECTRICAL SPECIFICATIONS:

Frequency Bands	AWS-1/AWS-3/WCS Bands 1695MHz-1780MHz & 2110MHz-2360MHz	PCS Band 1850MHz-2000MHz
Passband Insertion Loss	0.20dB	
Isolation	≥40dB @ 1850MHz-2000MHz	≥40dB @ 1695MHz-1780MHz & 2110MHz-2360MHz
Return Loss	21dB	
Impedance	50 Ohms	
Input Power	50 Watts (Avg); 250 Watts (Peak)	
DC Pass Current	4000 mA (Typ)	
Lightning Protection	8/20S 10kA Pulse (IEC 801-5)	
Intermodulation (PIM - 3 rd)	-161 dBc (2 Tones +43 dBm)	

MECHANICAL SPECIFICATIONS:

Connectors:	7/16 DIN (D) / Mini-DIN (MD) 4.3-10 (D43) / Type-N (N)
Housing Finish:	Aluminum Body
Mounting Method:	Mounting Panel
Temperature Range:	-20°C to 70°C
Relative Humidity:	5% - 95%
Environment:	IP67

***** ORDERING INFO:**

Single Model:	Part#: 901C-1925-1985-*
Stacked Model:	Part#: 902C-1925-1985-*
Twin Model:	Part#: 903C-1925-1985-*
Quad Model:	Part#: 904C-1925-1985-*

* - Connector Option

Block Diagram for 901C-1925-1985

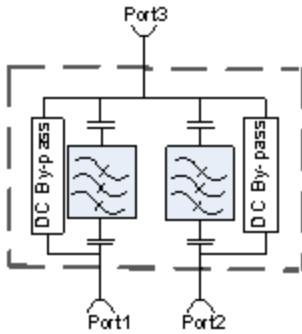

Block Diagram for 903C-1925-1985

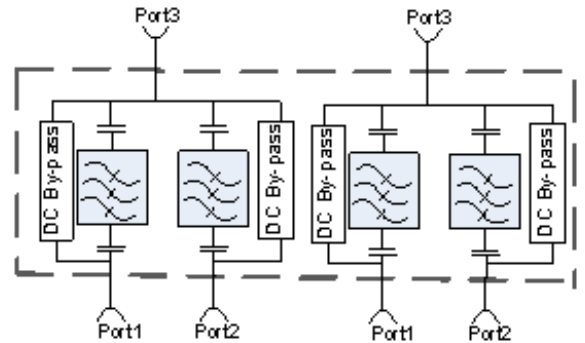

Dimensions for 901C-1925-1985-D43 (Single Model)

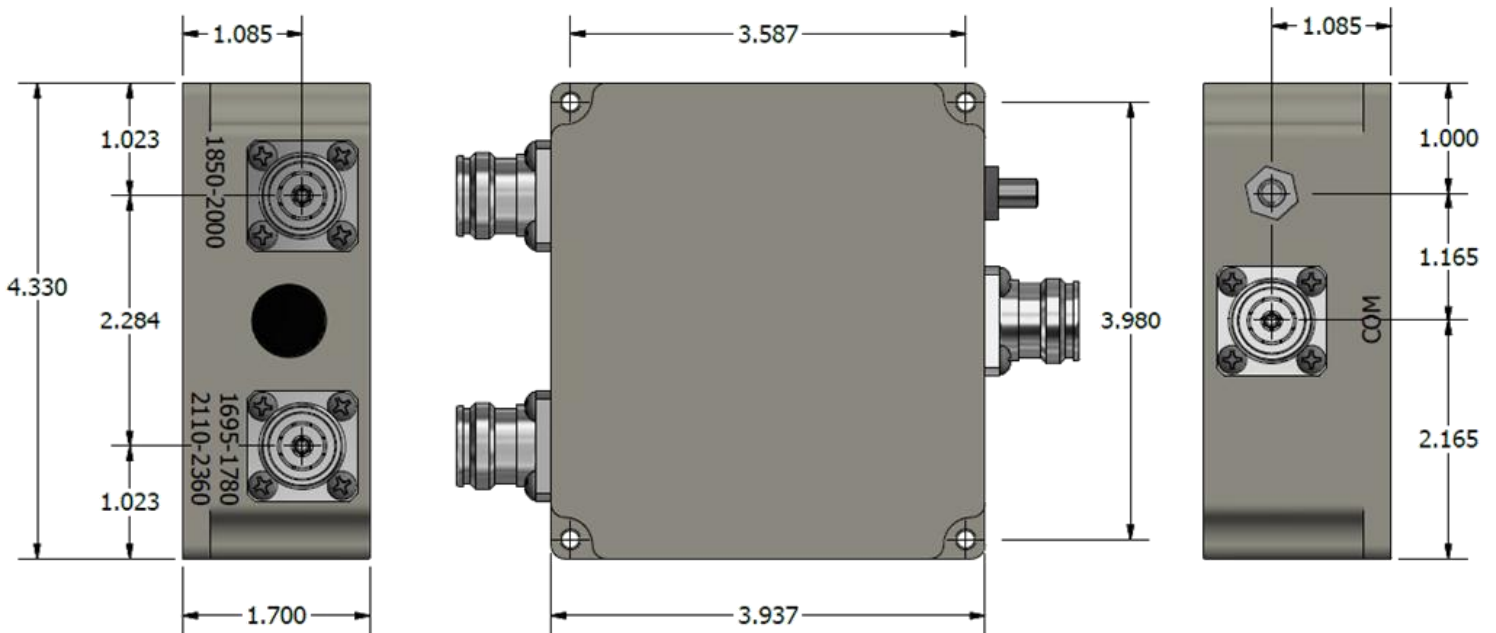

Dimensions for 902C-1925-1985-D43 (Stacked Model)

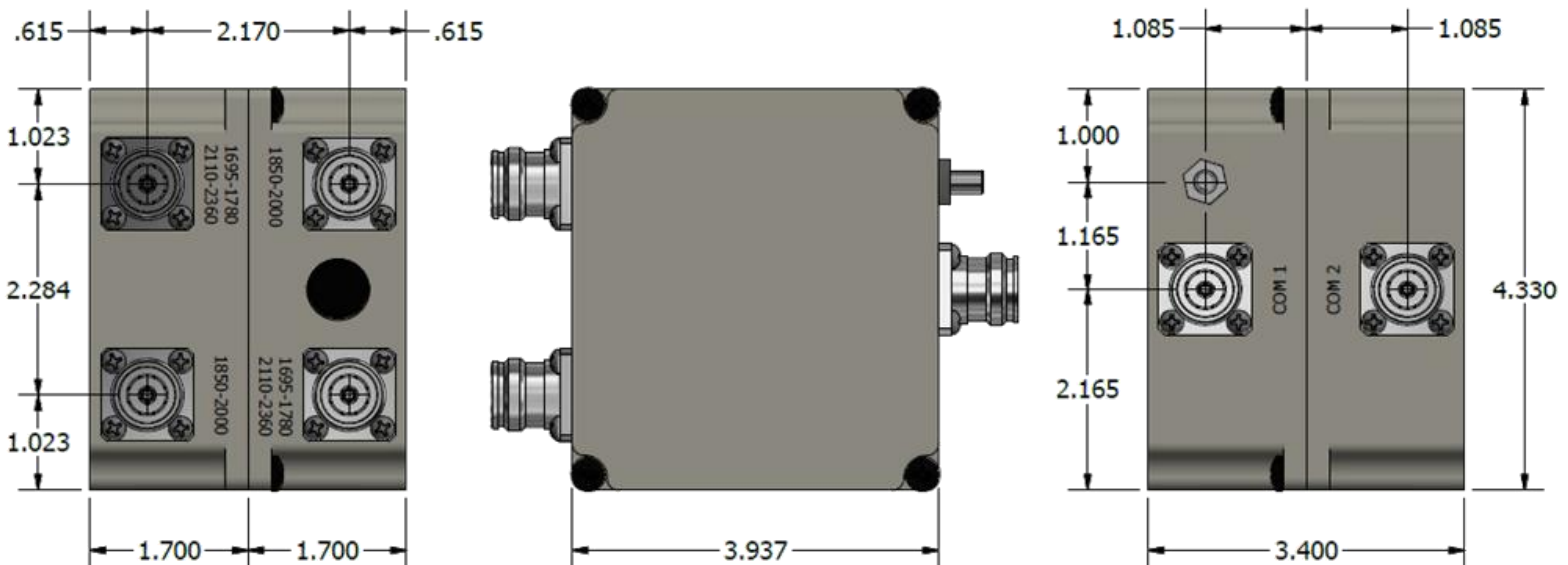

Dimensions for 903C-1925-1985-D43 (Twin Model)

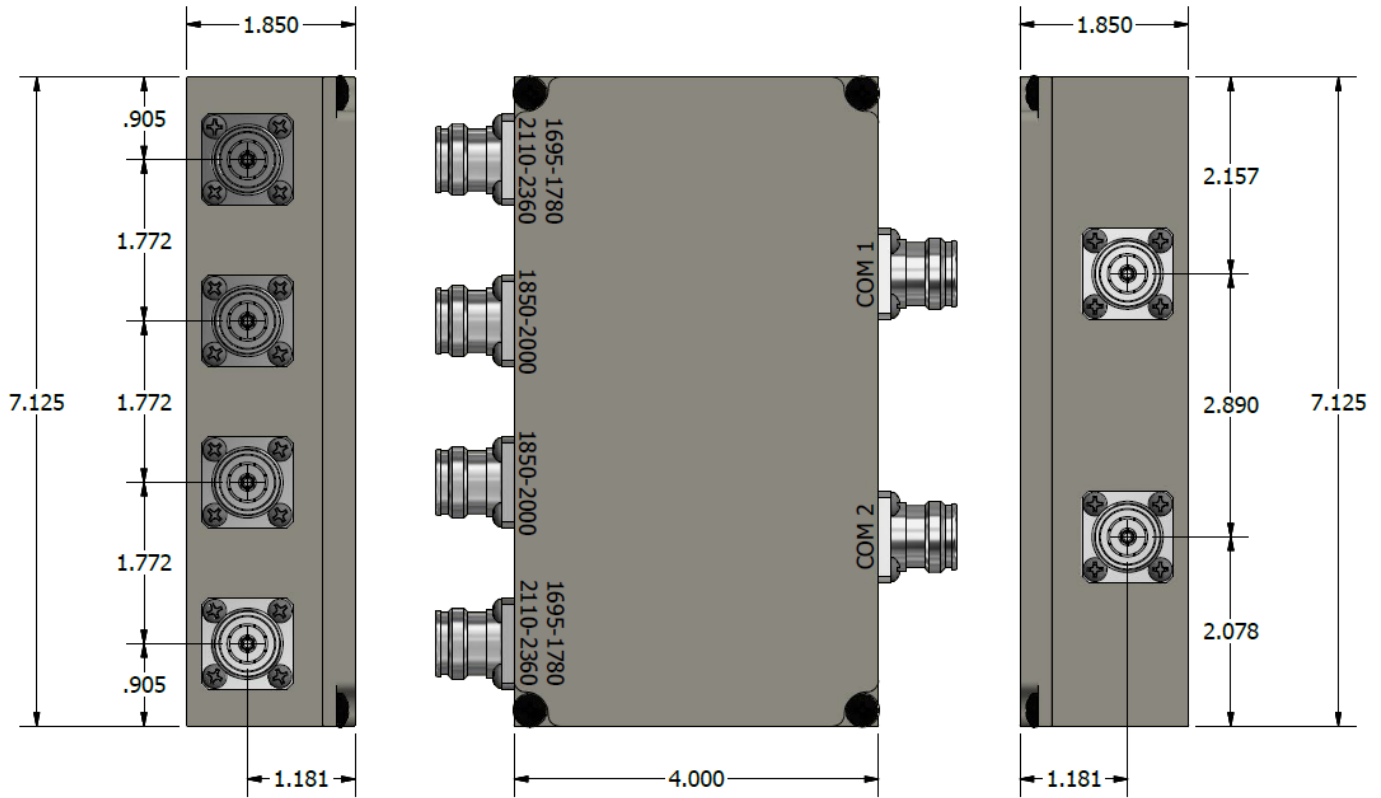

Dimensions for 904C-1925-1985-D43 (Quad Model)

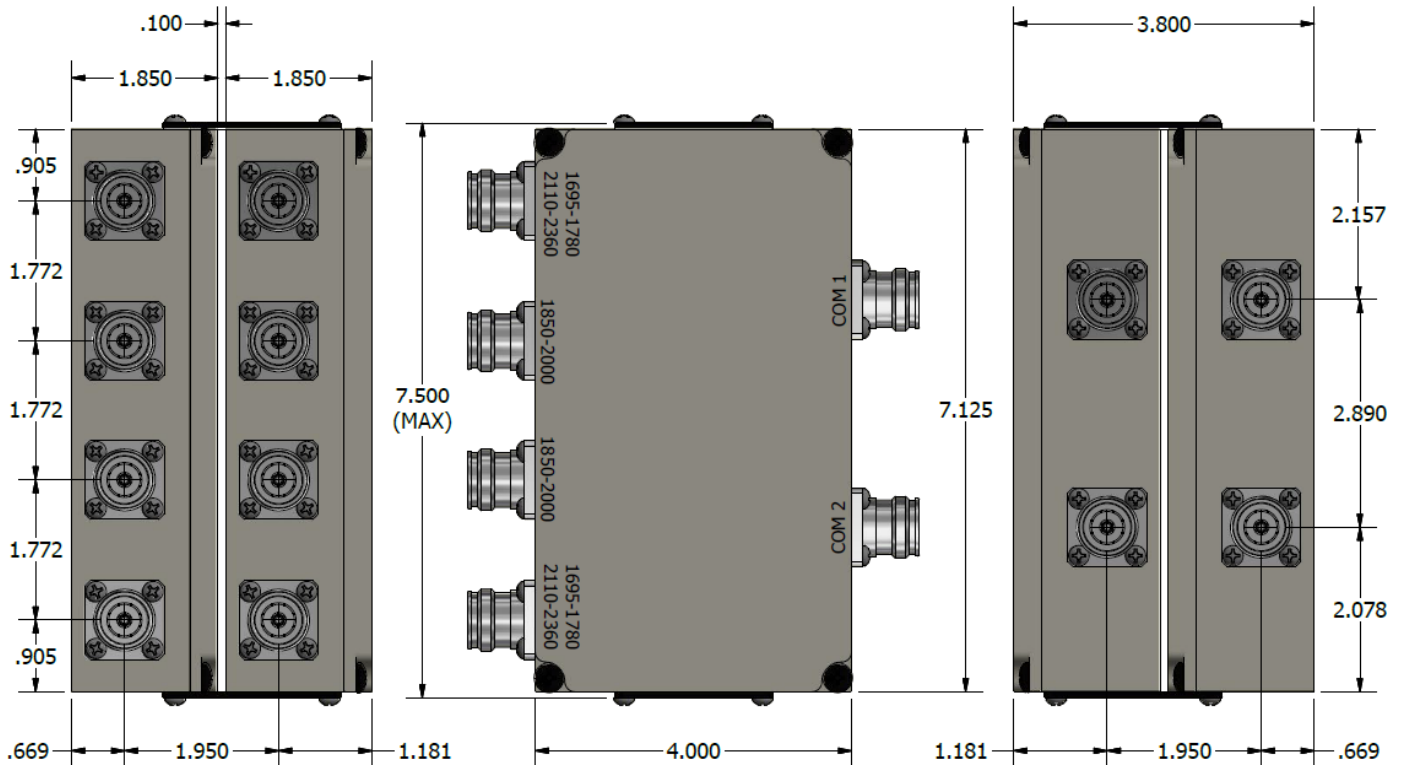

Please contact our sales department at 737-200-7090 or sales@InnowaveRF.com for any custom requirements.

© Innowave RF, LLC. All Rights Reserved. Specs can change without notice. Drawings are for reference purpose only.