

Innovation in Every Wave

FEATURES:

- Splits or combines **700LTE Band** (698MHz-787MHz), **GSM, CDMA Bands** (806MHz-960MHz), **PCS, AWS-1, AWS-3 Bands** (1695MHz-2180MHz) and **WCS, 2600LTE Bands** (2300MHz-2690MHz)
- Excellent Isolation between the bands
- Very low Insertion Loss with superior out of band rejections
- Available in DIN, Mini-DIN, 4.3-10 or Type-N Connectors
- Ease of Mounting with mounting holes and brackets
- Low-PIM with High Power Handling
- RoHS Complaint
- Weatherproof for Outdoor installation
- In Stock and Available Immediately

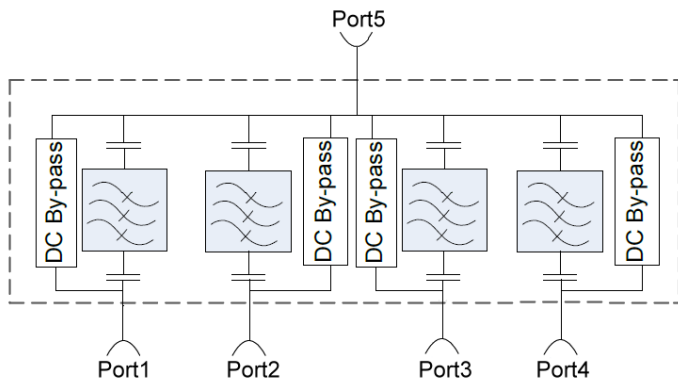

ELECTRICAL SPECIFICATIONS:

Frequency Bands	700 LTE	GSM, CDMA	PCS, AWS-1, AWS-3	WCS, 2600 LTE
	698MHz - 787MHz	806MHz - 960MHz	1695MHz - 2180MHz	2300MHz - 2690MHz
Passband Insertion Loss	0.25 dB			
Isolation	≥ 65 dB			
Return Loss	21 dB			
Impedance	50 Ohms			
Input Power	250 Watts (Avg); 2500 Watts (Peak)			
DC Pass Current	4000 mA (Typ)			
Intermodulation (PIM-3 rd)	-161dBc (2 Tones +43 dBm)			
Lightning Protection	8/20S 10KA Pulse (IEC801-5)			
MTBF Hours	≥ 500,000			

MECHANICAL SPECIFICATIONS:

Connectors: 7/16 DIN (D) / Mini-DIN (MD) / 4.3-10 (D43) / Type-N (N)
 Housing Finish: Aluminum Body
 Mounting Method: Mounting Panel
 Temperature Range: -35°C to 75°C
 Relative Humidity: 5% - 95%
 Environment: IP67

***** ORDERING INFO:**

Single Model: Part#: 941-820-2490-*

Dual Model: Part#: 942-820-2490-*

* - Connector Option

Dimensions for 941-820-2490-D

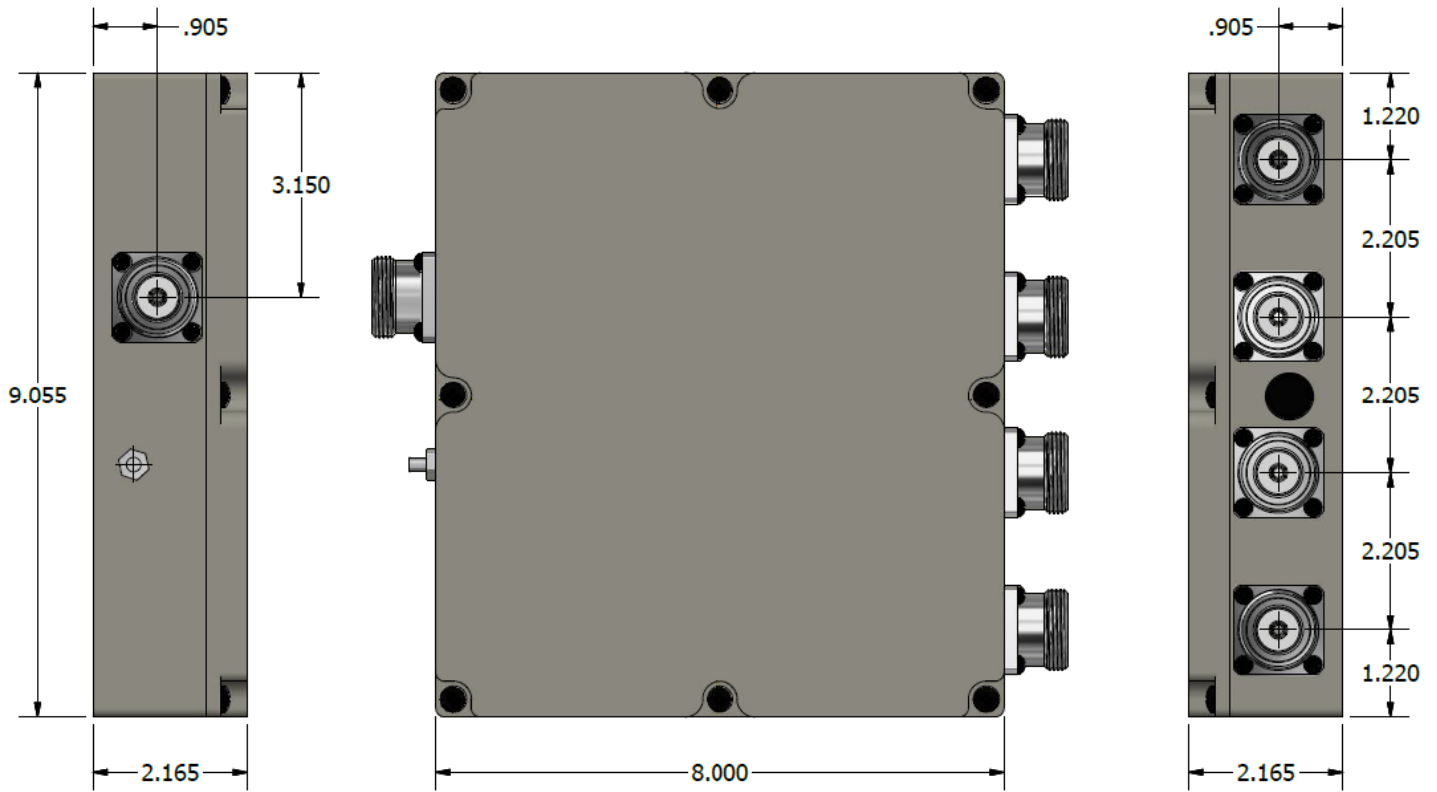

Dimensions for 942-820-2490-D

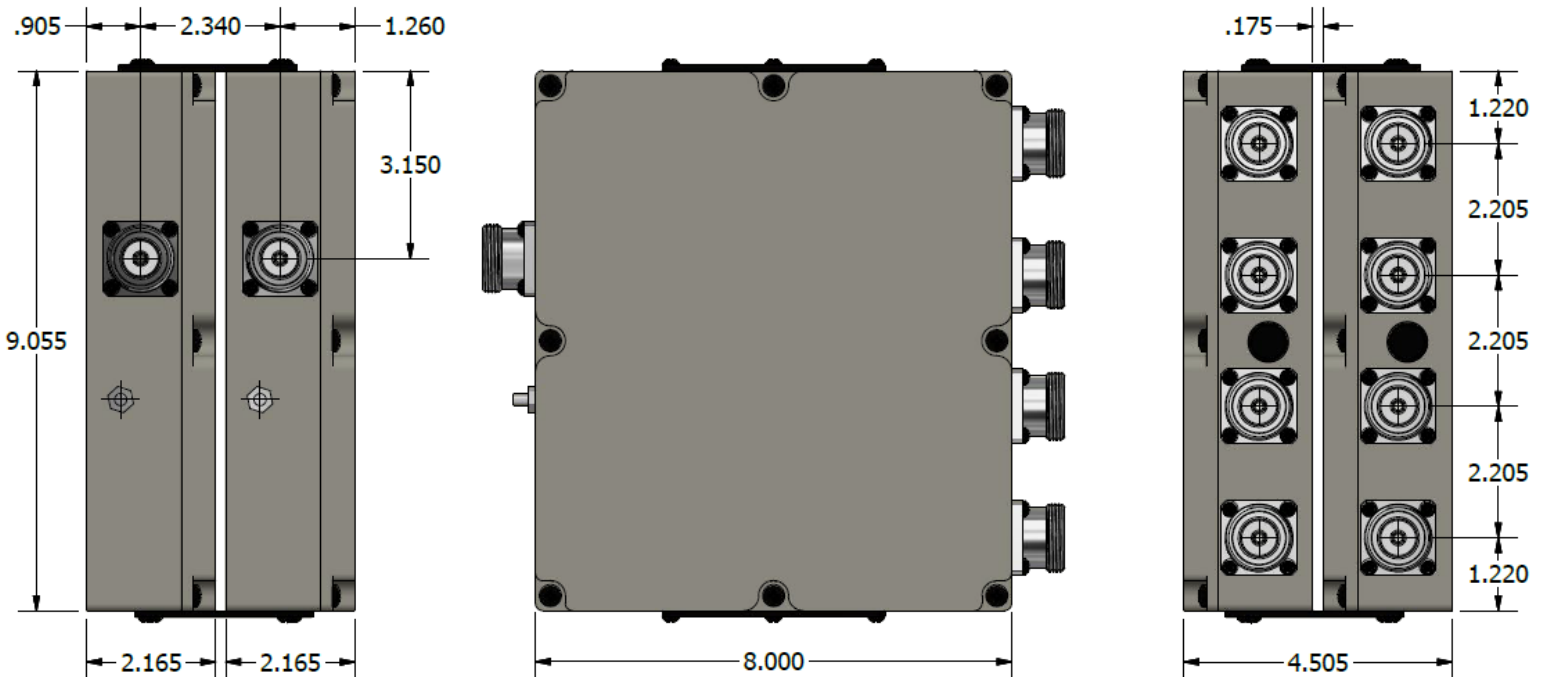

Please contact our sales department at 737-200-7090 or sales@InnowaveRF.com for any custom requirements.

© Innowave RF, LLC. All Rights Reserved. Specs can change without notice. Drawings are for reference purpose only.