

FEATURES:

- Splits or combines the Uplink (890-915) and Downlink (935-960) frequencies within the **900MHz Primary GSM Band**
- Best-in-class Isolation between the 2 signals
- Very low Insertion Loss with superior out of band rejections
- Low-PIM with High Power Handling
- -161dBc PIM and DC By-Pass available on request
- Available in Type-N, 7/16 DIN, Mini-DIN and 4.3-10 Connectors
- Weatherproof / Outdoor unit (*921W Series*) also available
- RoHS Complaint
- In Stock to low lead time delivery

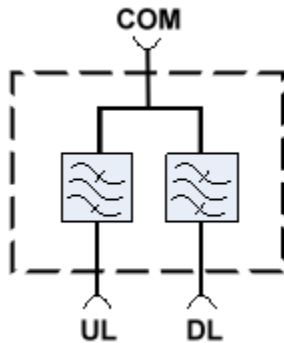

Block Diagram for 921-902-948



ELECTRICAL SPECIFICATIONS:

Frequency Bands	Downlink Freq 935MHz - 960MHz	Uplink Freq 890MHz - 915MHz
Passband Insertion Loss	0.35 dB	
Isolation	75dB @ 890MHz - 915MHz	75dB @ 935MHz - 960MHz
Return Loss	22 dB	
Impedance	50 Ohms	
DC Pass Current	4000 mA (Typ) (Available on Request)	
Lightning Protection	8/20S 10kA Pulse (IEC 801-5) (Available on Request)	
Input Power	250 Watts (Avg); 500 Watts (Peak)	
Intermodulation (PIM - 3 rd)	-157 dBc (2 Tones +43 dBm)	

MECHANICAL SPECIFICATIONS:

Connectors:	7/16 DIN (D) / Mini-DIN (MD) / 4.3-10 (D43) / Type-N (N)
Housing Finish:	Aluminum Body
Mounting Method:	Mounting Bracket
Temperature Range:	-35°C to 75°C
Relative Humidity:	5% - 95%
Environment:	IP65 (Indoor) IP67 (Outdoor)

***** ORDERING INFO:**

Indoor Model: Part#: 921-902-948-*

Outdoor Model: Part#: 921W-902-948-*

* - Connector Option

Dimensions for 921-902-948-N

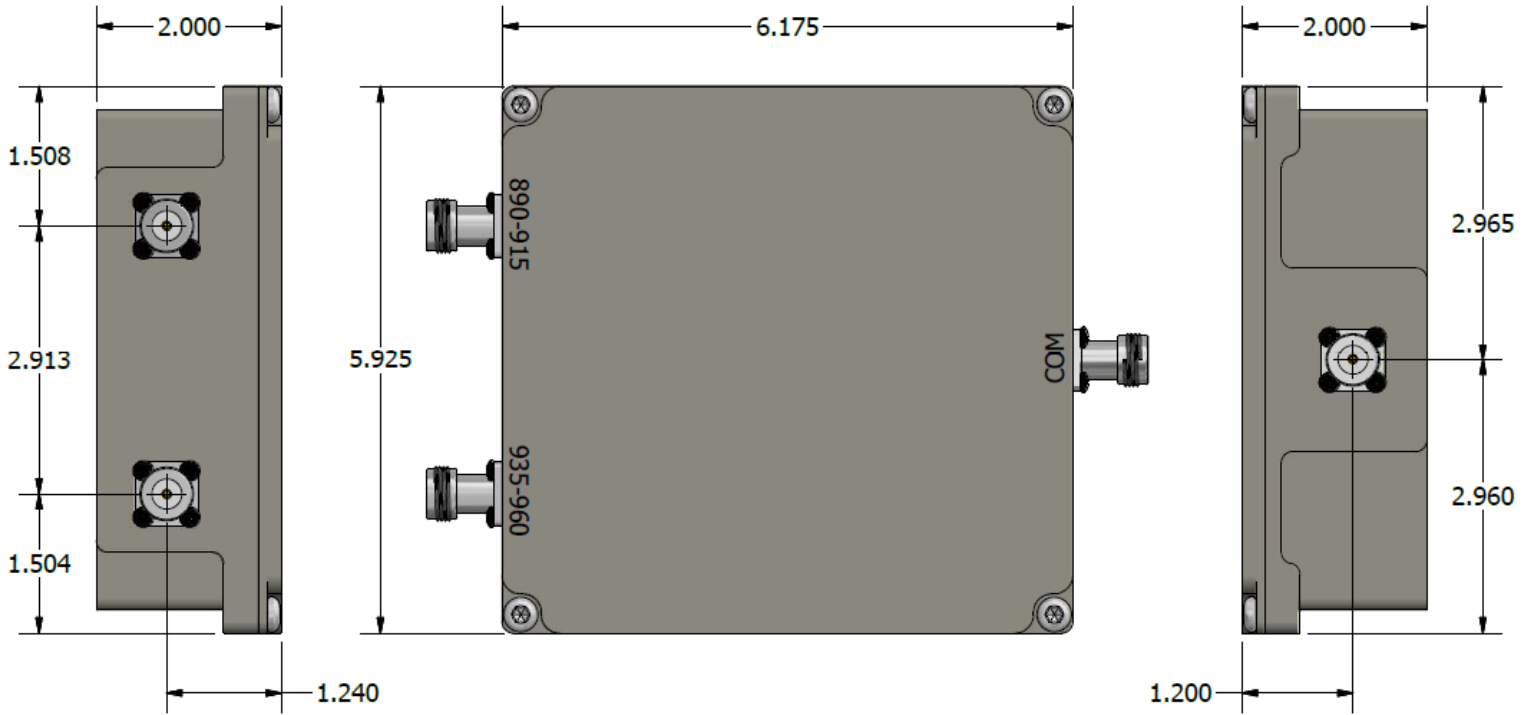

Dimensions for 921-902-948-D

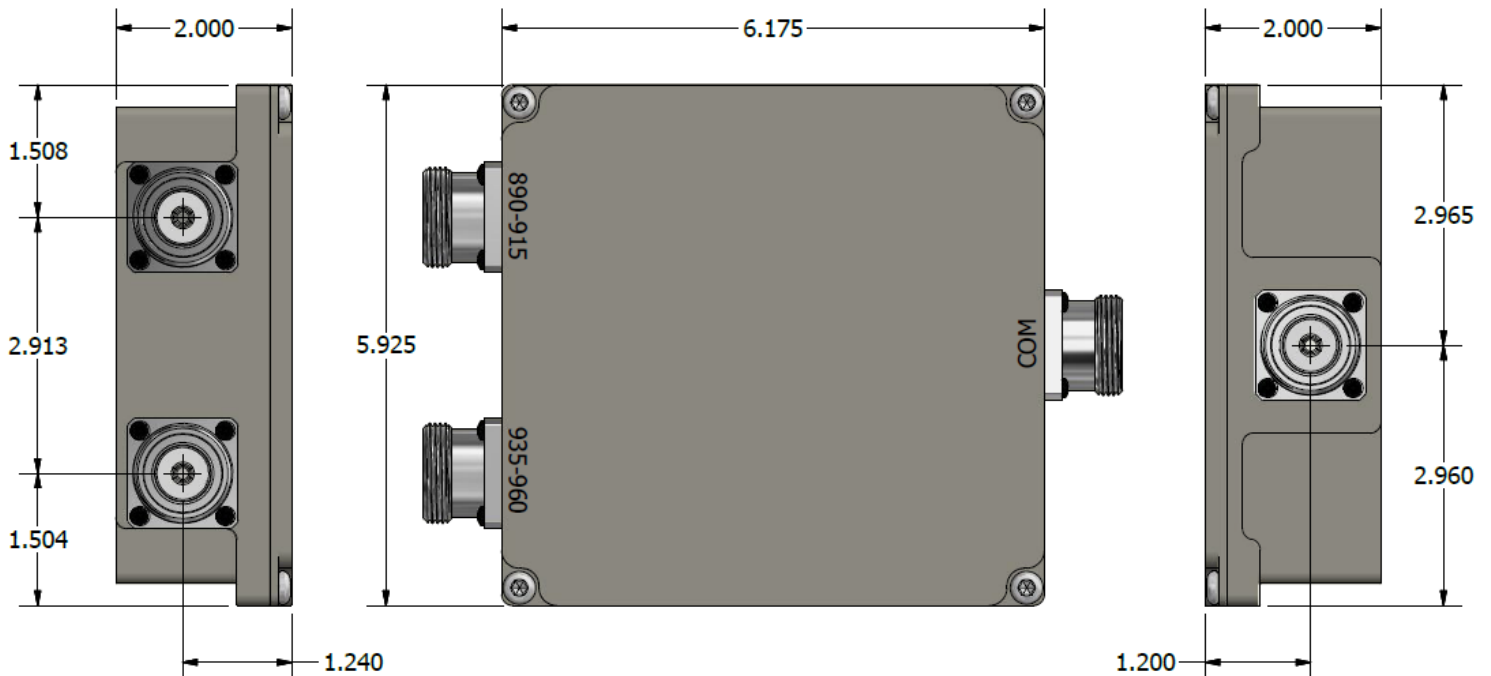

Please contact our sales department at 737-200-7090 or sales@InnowaveRF.com for any custom requirements.

© Innowave RF, LLC. All Rights Reserved. Specs can change without notice. Drawings are for reference purpose only.